



10623 Roselle Street, San Diego, CA 92121 • (858) 550-9559 • FAX (858) 550-7322  
contactus@acesio.com • www.acesio.com

**MODEL LPCI-COM-8SM**

**LPCI-COM-4SM**

**LPCI-COM232-8**

**LPCI-COM232-4**

**Low Profile PCI Multi-Port Serial  
Communications Cards**

**USER MANUAL**

FILE: MLPCI-COM-8SM.B7

## Notice

The information in this document is provided for reference only. ACCES does not assume any liability arising out of the application or use of the information or products described herein. This document may contain or reference information and products protected by copyrights or patents and does not convey any license under the patent rights of ACCES, nor the rights of others.

IBM PC, PC/XT, and PC/AT are registered trademarks of the International Business Machines Corporation.

Printed in USA. Copyright 2004, 2005 by ACCES I/O Products Inc, 10623 Roselle Street, San Diego, CA 92121. All rights reserved.

## WARNING!!

**ALWAYS CONNECT AND DISCONNECT YOUR FIELD CABLING WITH THE COMPUTER POWER OFF. ALWAYS TURN COMPUTER POWER OFF BEFORE INSTALLING A CARD. CONNECTING AND DISCONNECTING CABLES, OR INSTALLING CARDS INTO A SYSTEM WITH THE COMPUTER OR FIELD POWER ON MAY CAUSE DAMAGE TO THE I/O CARD AND WILL VOID ALL WARRANTIES, IMPLIED OR EXPRESSED.**

## **Warranty**

Prior to shipment, ACCES equipment is thoroughly inspected and tested to applicable specifications. However, should equipment failure occur, ACCES assures its customers that prompt service and support will be available. All equipment originally manufactured by ACCES which is found to be defective will be repaired or replaced subject to the following considerations.

## **Terms and Conditions**

If a unit is suspected of failure, contact ACCES' Customer Service department. Be prepared to give the unit model number, serial number, and a description of the failure symptom(s). We may suggest some simple tests to confirm the failure. We will assign a Return Material Authorization (RMA) number which must appear on the outer label of the return package. All units/components should be properly packed for handling and returned with freight prepaid to the ACCES designated Service Center, and will be returned to the customer's/user's site freight prepaid and invoiced.

## **Coverage**

First Three Years: Returned unit/part will be repaired and/or replaced at ACCES option with no charge for labor or parts not excluded by warranty. Warranty commences with equipment shipment.

Following Years: Throughout your equipment's lifetime, ACCES stands ready to provide on-site or in-plant service at reasonable rates similar to those of other manufacturers in the industry.

## **Equipment Not Manufactured by ACCES**

Equipment provided but not manufactured by ACCES is warranted and will be repaired according to the terms and conditions of the respective equipment manufacturer's warranty.

## **General**

Under this Warranty, liability of ACCES is limited to replacing, repairing or issuing credit (at ACCES discretion) for any products which are proved to be defective during the warranty period. In no case is ACCES liable for consequential or special damage arriving from use or misuse of our product. The customer is responsible for all charges caused by modifications or additions to ACCES equipment not approved in writing by ACCES or, if in ACCES opinion the equipment has been subjected to abnormal use. "Abnormal use" for purposes of this warranty is defined as any use to which the equipment is exposed other than that use specified or intended as evidenced by purchase or sales representation. Other than the above, no other warranty, expressed or implied, shall apply to any and all such equipment furnished or sold by ACCES.

## Table of Contents

<b>Chapter 1: Introduction</b> .....	5
<b>Features</b> .....	5
<b>Applications</b> .....	5
<b>Functional Description</b> .....	5
<b>RS422 Balanced Mode Operation</b> .....	5
<b>RS485 Balanced Mode Operation</b> .....	6
<b>COM Port Compatibility</b> .....	6
<b>Communication Mode</b> .....	6
<b>Baud Rate Ranges</b> .....	6
<b>Auto-RTS Transceiver Control</b> .....	7
<b>Figure 1-1: Block Diagram (Only one serial channel shown)</b> .....	7
<b>Ordering Guide</b> .....	8
<b>Model Options</b> .....	8
<b>Optional Accessories</b> .....	8
<b>Special Order</b> .....	8
<b>Included with your board</b> .....	8
<b>Chapter 2: Installation</b> .....	9
<b>Configure Card Options via Jumper Selection</b> .....	9
<b>CD Software Installation</b> .....	9
<b>Chapter 3: Option Selection</b> .....	11
<b>Terminations</b> .....	11
<b>Figure 3-1: Simplified Termination Schematic</b> .....	11
<b>Data Cable Wiring</b> .....	11
<b>Baud Rate Ranges</b> .....	12
<b>Interrupts</b> .....	12
<b>Table 3-1: WindowsNT Registry Values</b> .....	12
<b>Figure 3-2: Option Selection Map</b> .....	13
<b>Other jumpers</b> .....	14
<b>Chapter 4: Address Selection</b> .....	15
<b>Chapter 5: Programming</b> .....	16
<b>Address Map</b> .....	17
<b>Baud Rates</b> .....	17
<b>Table 5-1: Baud Rate Divisor Values</b> .....	17
<b>Chapter 6: Connector Pin Assignments</b> .....	18
<b>Input/Output Connections</b> .....	18
<b>Table 6-1: Connector Pin Assignments</b> .....	18
<b>Chapter 7: Specifications</b> .....	19
<b>Communications Interface</b> .....	19
<b>Environmental</b> .....	19
<b>Appendix A: Application Considerations</b> .....	20
<b>Table A-1: Connections Between Two RS422 Devices</b> .....	20
<b>Table A-2: RS422 Specification Summary</b> .....	21
<b>Figure A-1: Typical RS485 Two-Wire Multidrop Network</b> .....	22
<b>Appendix B: HVDCI D-Connector Pinout Reference</b> .....	23
<b>Table B-1: HVDCI D-Connector Pin Assignments</b> .....	23
<b>Customer Comments</b> .....	24

## Chapter 1: Introduction

This serial interface card was designed for effective multipoint transmission in any one of three modes on each channel. These modes are RS232, RS422 and RS485 (EIA485) protocol. The RS485 mode may be run in three manners. It may be run as a standard RTS controlled channel, an "Auto RTS (referred to by some as Auto RS485)" mode or as a "4 wire RS485 mode channel.

The card is 6.60 inches long and may be installed in 3.3 or 5-volt PCI-bus slots of IBM PC or compatible computers. The card features eight independent, asynchronous serial ports, type 16788 buffered UARTs.

This series of cards are available in 4-port and RS-232 only versions.

### Features

- Eight- or four-port RS-232/422/485 serial communications
- High performance 16788 class UARTs with 64-byte FIFO for each TX and RX
- Supports data communication speeds up to 921.6kbps
- Software compatible with all operating systems
- 6' breakout cable terminating with industry-standard DB9M connectors

### Applications

- POS (Point-of-sale) Systems
- Gaming Machines
- Transportation Stations
- Telecommunications
- Industrial Automation
- ATM (Automated Teller Machine) Systems
- Multiple terminal control
- Office Automation
- Kiosks

### Functional Description

#### RS422 Balanced Mode Operation

The card supports RS422 communications and uses differential balanced drivers for long range and noise immunity. The card also has the capability to add load resistors to terminate the communications lines. RS422 communications requires that a transmitter supply a bias voltage to ensure a known "zero" state. Also, receiver inputs at each end of the network should be terminated to eliminate "ringing". The card supports biasing by default and supports termination by jumpers on the card. If your application requires the transmitter to be un-biased, please contact the factory.

## **RS485 Balanced Mode Operation**

The card supports RS485 communications and uses differential balanced drivers for long range and noise immunity. RS485 operation involves switchable transceivers and the ability to support multiple devices on a single "party line". The RS485 specification defines a maximum of 32 devices on a single line. The number of devices served on a single line can be expanded by use of "repeaters".

The card also has the capability to add load resistors to terminate the communications lines. RS485 communications requires that one transmitter supply a bias voltage to ensure a known "zero" state when all transmitters are off. Also, receiver inputs at each end of the network should be terminated to eliminate "ringing". The card supports biasing by default and supports termination by jumpers on the card. If your application requires the transmitter to be un-biased, please contact the factory.

## **COM Port Compatibility**

Eight Type 16550 compatible UARTs incorporated within a single octal UART are used as Asynchronous Communication Elements (ACE). These include 64-byte transmit & receive buffers to protect against lost data in multitasking operating systems, while maintaining 100 percent compatibility with the original IBM serial port. The system assigns the address(es).

A crystal oscillator is located on the card. This oscillator permits precise selection of baud rate up to 115,200 or, by changing a jumper, up to 921,600 with the standard crystal oscillator.

The driver/receiver used, the SP841 in non-RS232 modes, is capable of driving extremely long communication lines at high baud rates. It can drive up to +60 mA on balanced lines and receive inputs as low as 200 mV differential signal superimposed on common mode noise of +12 V or -7 V. In case of communication conflict, the driver/receivers feature thermal shutdown.

The driver/receiver used in RS232 mode is the high-speed ICL3245.

## **Communication Mode**

The card supports Half-Duplex communications with a 2-wire cable connection. Half-Duplex allows traffic to travel in both directions, but only one way at a time. RS485 communications commonly use the Half-Duplex mode since they share only a single pair of wires.

## **Baud Rate Ranges**

The card has capability for two baud rate ranges and you can select which you wish to use for all ports on the card. One range is up to 115,200 baud and the other is up to 921,600 baud.

**Note:** Refer to Table 5-1: Baud Rate Divisor Values in chapter 5 of this manual.

## Auto-RTS Transceiver Control

In RS485 communications, the driver must be enabled and disabled as needed, allowing all cards to share a two wire cable. The card controls the driver automatically. With automatic control, the driver is enabled when data is ready to be transmitted.

With this card, the driver remains enabled for an adjustable period. It may be disabled at the completion of the transmission of the character (default), or can be set to wait up to one additional character's transmission time after data transfer is complete and then disabled.

The receiver is, therefore, normally enabled, then disabled during RS485 transmissions, and then re-enabled after transmission is completed (adjustable from zero to plus one character transmission time). The card automatically adjusts its timing to the baud rate of the data.

(NOTE: Thanks to the automatic control feature, the card is ideal for use in Windows applications)

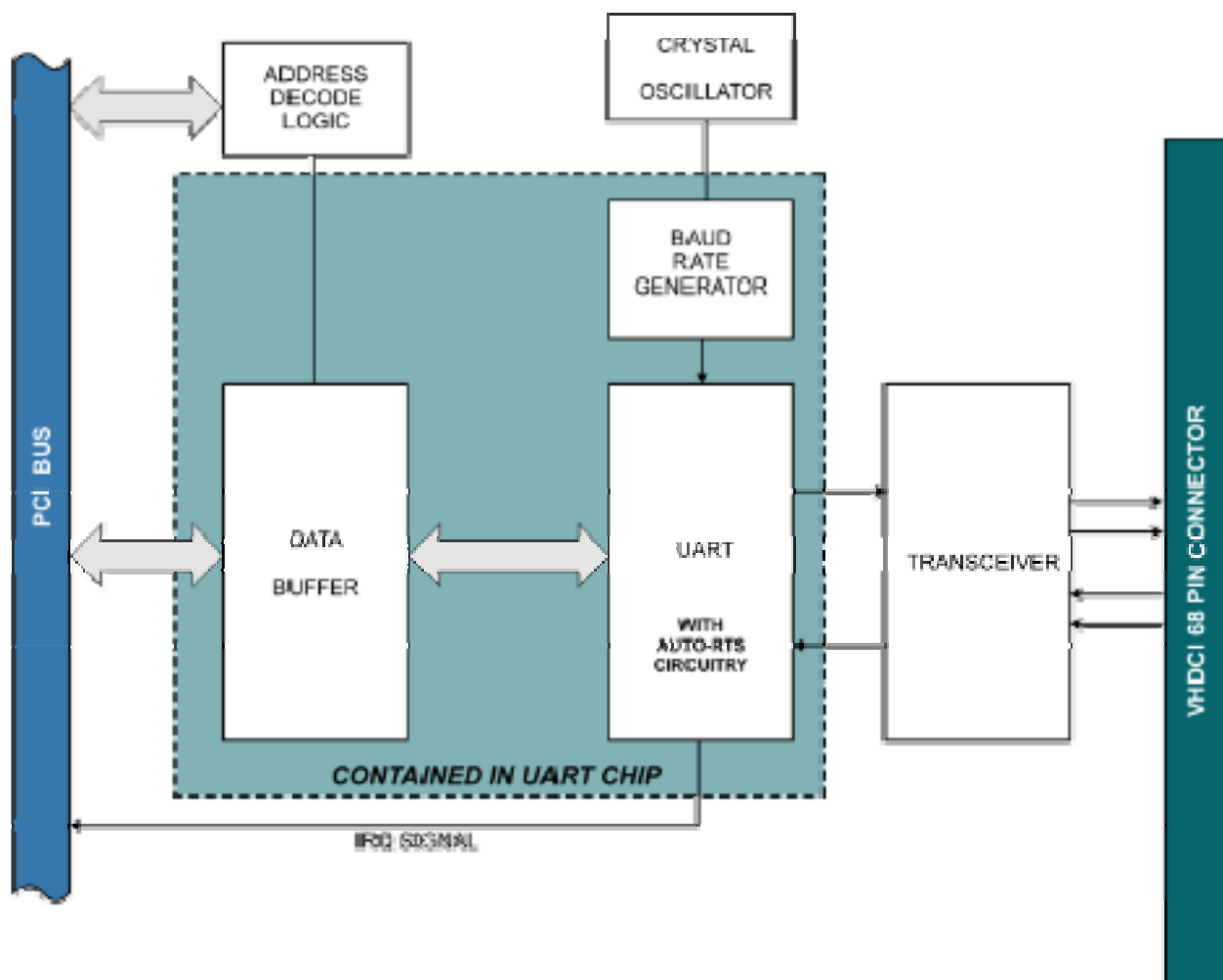

Figure 1-1: Block Diagram (Only one serial channel shown)

## Ordering Guide

- LPCI-COM-8SM Low Profile PCI eight-port RS-232/422/485 card with standard height mounting bracket and 6' DB9M cable
- LPCI-COM232-8 Low Profile PCI eight-port RS-232 card with standard height mounting bracket and 6' DB9M breakout cable
- LPCI-COM-8SM Low Profile PCI four-port RS-232/422/485 card with standard height mounting bracket and a 6' DB9M cable
- LPCI-COM232-4 Low Profile PCI four-port RS-232 card with standard height mounting bracket and a 6' DB9M breakout cable

## Model Options

- -L Low-profile mounting bracket
- -RoHS RoHS compliant version

## Optional Accessories

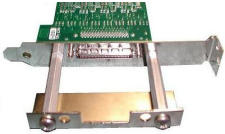
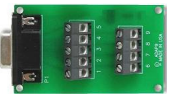
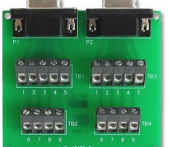
BRKT-551-SCB	Strengthening bracket (for use with standard height PCI bracket only)	
ADAP9	Screw terminal adaptor DB9F to 9 screw terminals	
ADAP9-2	Screw terminal adaptor with two DB9F connectors and 18 screw terminals	

## Special Order

Custom baud rates are available upon request. Contact factory with your precise requirement. Other specials: conformal coating, custom software, RJ-45 connectivity, special breakout boxes, etc., we will work with you to provide exactly what is required.

## Included with your board

The following components are included with your shipment, depending on options ordered. Please take the time now to ensure that no items are damaged or missing.

- **Eight- or four-port** card with standard height mounting bracket
- 6' breakout cable to DB9M connectors
- Software Master CD
- Quick-Start Guide



## Chapter 2: Installation

A printed Quick-Start Guide (QSG) is packed with the card for your convenience. If you've already performed the steps from the QSG, you may find this chapter to be redundant and may skip forward to begin developing your application.

The software provided with this card is on CD and must be installed onto your hard disk prior to use. To do this, perform the following steps as appropriate for your operating system.

### Configure Card Options via Jumper Selection

Before installing the card into your computer, carefully read Chapter 3: Option Selection of this manual, then configure the card according to your requirements and protocol (RS-232, RS-422, RS-485, 4-wire 485, etc.). Our Windows based setup program can be used in conjunction with Chapter 3 to assist in configuring jumpers on the card, as well as provide additional descriptions for usage of the various card options (such as termination, bias, baud rate range, RS-232, RS-422, RS-485, etc.).

### CD Software Installation

The following instructions assume the CD-ROM drive is drive "D". Please substitute the appropriate drive letter for your system as necessary.

#### DOS

1. Place the CD into your CD-ROM drive.
2. Type `D:\Enter` to change the active drive to the CD-ROM drive.
3. Type `I\N\S\T\A\L\L\Enter` to run the install program.
4. Follow the on-screen prompts to install the software for this board.

#### WINDOWS

1. Place the CD into your CD-ROM drive.
2. The system should automatically run the install program. If the install program does not run promptly, click START | RUN and type `D:\I\N\S\T\A\L\L`, click OK or press `Enter`.
3. Follow the on-screen prompts to install the software for this board.

#### LINUX

1. Please refer to linux.htm on the CD-ROM for information on installing under linux.

Note: COM boards can be installed in virtually any operating system. We do support installation in earlier versions of Windows, and are very likely to support future versions as well.

#### **Caution! \* ESD**

***A single static discharge can damage your card and cause premature failure! Please follow all reasonable precautions to prevent a static discharge such as grounding yourself by touching any grounded surface **prior to touching the card.*****

## Hardware Installation

1. Make sure to set switches and jumpers from either the Option Selection section of this manual or from the suggestions of SETUP.EXE.
2. Do not install card into the computer until the software has been fully installed.
3. Turn OFF computer power AND unplug AC power from the system.
4. Remove the computer cover.
5. Carefully install the card in an available 5V or 3.3V PCI expansion slot (you may need to remove a backplate first).
6. Inspect for proper fit of the card and tighten screws. Make sure that the card mounting bracket is properly screwed into place and that there is a positive chassis ground.
7. Install an I/O cable onto the card's bracket mounted connector.
8. Replace the computer cover and turn ON the computer. Enter the CMOS setup program of your system and verify that the PCI plug-and-play option is set appropriately for your system. Systems running Windows 95/98/2000/XP/2003 (or any other PNP-compliant operating system) should set the CMOS option to OS. Systems running under DOS, Windows NT, Windows 3.1, or any other non-PNP-compliant operating system should set the PNP CMOS option to BIOS or Motherboard. Save the option and continue booting the system.
9. Most computers should auto-detect the card (depending on the operating system) and automatically finish installing the drivers.
10. Run PCIFind.exe to complete installing the card into the registry (for Windows only) and to determine the assigned resources.
11. Run one of the provided sample programs that was copied to the newly created card directory (from the CD) to test and validate your installation.

The base address assigned by BIOS or the operating system can change each time new hardware is installed into or removed from the computer. Please recheck PCIFind or Device Manager if the hardware configuration is changed. Software you write can automatically determine the base address of the card using a variety of methods depending on the operating system. In DOS, the PCI\SOURCE directory shows the BIOS calls used to determine the address and IRQ assigned to installed PCI devices. In Windows, the Windows sample programs demonstrate querying the registry entries (created by PCIFind and NTIOPCI.SYS during boot-up) to determine this same information.

## Chapter 3: Option Selection

To help you locate the jumpers described in this section, refer to the Option Selection Map at the end of this section. Operation of the serial communications section is determined by jumper installation as described in the following paragraphs.

For the convenience of the user, instructions for the placement of the jumpers is also silk screened on the back of the card.

### Terminations

A transmission line should be terminated at the receiving end in its characteristic impedance. Installing a jumper at the locations labeled LDxO applies a 120Ω load across the transmit/receive input/output for RS485 operation.

Jumpers having to do with the termination of each channel are located near the output connector. They are labeled by channel. The load jumper is labeled “LD”. The other two jumpers are used to connect the transmit and receive lines for the two wire RS485 mode.

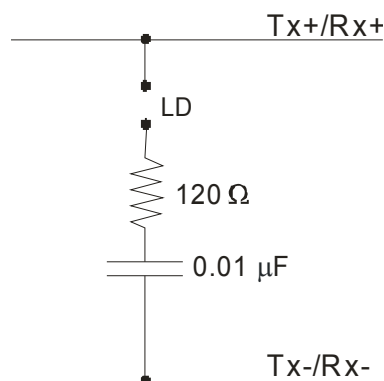

**Figure 3-1: Simplified Termination Schematic**

In RS485 operations where there are multiple terminals, only the RS485 ports at each end of the network should have terminating impedance as described above. To so terminate the COM A port, place a jumper at the location labeled Ch A -LD. To terminate the COM B, COM C, COM D, COM E, COM F and COM H ports, place jumpers at locations labeled Ch B - LD, Ch C - LD, Ch D - LD, Ch E - LD, Ch F - LD, Ch G - LD and Ch H - LD respectively.

Also, for RS485 operation, there must be a bias on the TRX+ and TRX- lines. If the card is not to provide that bias, contact the factory technical support.

### Data Cable Wiring

#### RS-485 Signal Pin Connection

Ain/out+	2
Ain/out-	3
100 Ω to Ground	5

## Baud Rate Ranges

The jumper labeled CLK X8 provides a means to select baud rates in a higher range. When a jumper is not placed on the out the CLK X8 position, the baud rate range is up to 115,200 baud. When it is in the CLK X8 position, the baud rate range is up to 921,600 baud.

## Interrupts

Please note that, in WindowsNT, changes must be made to the system registry to support IRQ sharing. The following is excerpted from "Controlling Multiport Serial I/O Cards" provided by Microsoft in the MSDN library, documentid:mk:@ivt:nt40res/D15/S55FC.HTM, also available in the WindowsNT Resource Kit.

The Microsoft serial driver can be used to control many dumb multiport serial cards. Dumb indicates that the control includes no on-board processor. Each port of a multiport card has a separate subkey under the HKLM\CurrentControlSet\Services\Serial subkey in the registry. In each of these subkeys, you must add values for **DosDevices**, **Interrupt**, **InterruptStatus**, **PortAddress**, and **PortIndex** because these are not detected by the Hardware Recognizer. (For descriptions and ranges for these values, see Regentry.hlp, the Registry help file on the WindowsNT Workstation Resource Kit CD.)

For example, if you have an eight-port card configured to use address 0xFC00 with an interrupt of 05, the values in the Registry are:

### Serial2 subkey:

PortAddress = REG\_DWORD 0xFC00  
Interrupt = REG\_DWORD 5  
DosDevices = REG\_SZ COM3  
InterruptStatus = REG\_DWORD 0xFC40  
PortIndex = REG\_DWORD 1  
Indexed = REG\_DWORD 0

### Serial3 subkey:

PortAddress = REG\_DWORD 0xFC08  
Interrupt = REG\_DWORD 5  
DosDevices = REG\_SZ COM4  
InterruptStatus = REG\_DWORD 0xFC40  
PortIndex = REG\_DWORD 2  
Indexed = REG\_DWORD 0

### Serial4 subkey:

PortAddress = REG\_DWORD 0xFC10  
Interrupt = REG\_DWORD 5  
DosDevices = REG\_SZ COM5  
InterruptStatus = REG\_DWORD 0xFC40  
PortIndex = REG\_DWORD 3  
Indexed = REG\_DWORD 0

### Serial5 subkey:

PortAddress = REG\_DWORD 0xFC18  
Interrupt = REG\_DWORD 5  
DosDevices = REG\_SZ COM6  
InterruptStatus = REG\_DWORD 0xFC40  
PortIndex = REG\_DWORD 4  
Indexed = REG\_DWORD 0

### Serial6 subkey:

PortAddress = REG\_DWORD 0xFC20  
Interrupt = REG\_DWORD 5  
DosDevices = REG\_SZ COM7  
InterruptStatus = REG\_DWORD 0xFC40  
PortIndex = REG\_DWORD 5  
Indexed = REG\_DWORD 0

### Serial7 subkey:

PortAddress = REG\_DWORD 0xFC28  
Interrupt = REG\_DWORD 5  
DosDevices = REG\_SZ COM8  
InterruptStatus = REG\_DWORD 0xFC40  
PortIndex = REG\_DWORD 6  
Indexed = REG\_DWORD 0

### Serial8 subkey:

PortAddress = REG\_DWORD 0xFC30  
Interrupt = REG\_DWORD 5  
DosDevices = REG\_SZ COM9  
InterruptStatus = REG\_DWORD 0xFC40  
PortIndex = REG\_DWORD 7  
Indexed = REG\_DWORD 0

### Serial9 subkey:

PortAddress = REG\_DWORD 0xFC38  
Interrupt = REG\_DWORD 5  
DosDevices = REG\_SZ COM10  
InterruptStatus = REG\_DWORD 0xFC40  
PortIndex = REG\_DWORD 8  
Indexed = REG\_DWORD 0

**Table 3-1: WindowsNT Registry Values**

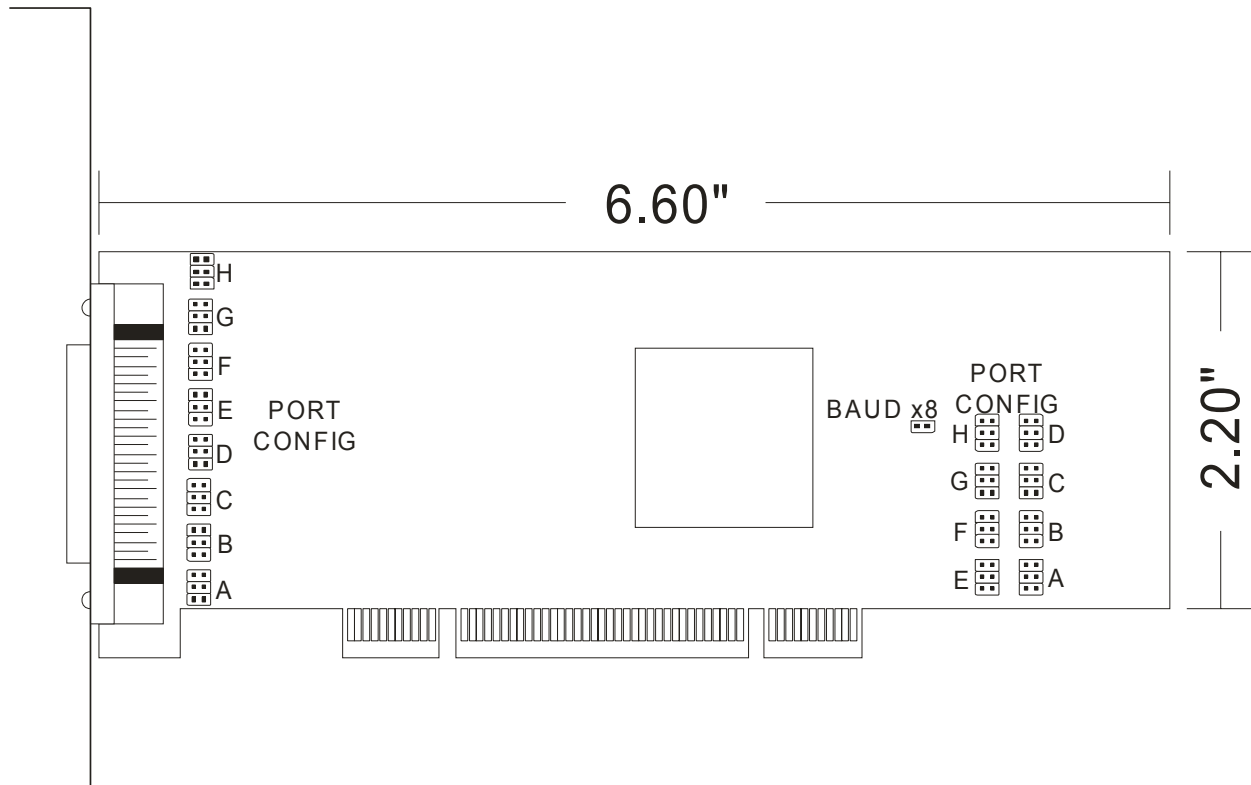

**Figure 3-2:** Option Selection Map

The card has 8 separate channels which can be individually configured. Each channel can be used in:

- 1) RS485 (2 wire mode) - This mode may use "Auto RTS"
- 2) RS422
- 3) RS232
- 4) RS485 (4 wire mode)

The jumpers on the card must be properly placed in order to have the card function properly.

In order to select the basic mode for a channel, the M1 and M2 jumpers must be properly placed. (These jumpers are located at the end of the card away from the cable connector).

Mode	M1	M2
RS485 (2 Wire Mode)	IN	OUT
RS485 (4 Wire Mode)	OUT	IN
RS422	IN	IN
RS232	OUT	OUT

## **Other jumpers**

- 1) RS 485 (2 wire mode) - Two jumpers must be installed for each channel in this mode in order to connect the output and input lines. These jumpers are located near the cable connector and are labeled with the channel letter and "485."
- 2) RS 485 (2 wire mode) using "Auto RTS" - One jumper must be installed for each channel in this mode. This jumper is located at the end of the card away from the cable connector, adjacent to the "M" jumpers and are labeled with the channel letter and "A8".
- 3) RS 485 or RS 422 Loads - One jumper must be installed for each channel which requires a load. This jumper is located at the cable connector end of the card and is labeled with the channel letter and "LD."

## **Notes:**

- 1) Any unneeded jumpers that are installed can cause the card to function incorrectly.
- 2) If the "Auto RTS" jumpers are changed, the card should be rebooted or reset. This is required because the status of the jumpers is read when the card is reset and is used to program the Auto RTS function into the appropriate channel(s) of the UART. If the state of this jumper is changed, the UART will not be properly programmed until the jumper has been reread. To do this, the card must be reset.

## Chapter 4: Address Selection

The card uses one address space. COM A, COM B, COM C, COM D, COM E, COM F, COM G and COM H each occupy eight consecutive register locations. The interrupt register which indicates which port or ports caused the interrupt is located at base address + 64.

PCI architecture is Plug-and-Play. This means that the BIOS or Operating System determines the resources assigned to PCI cards rather than you selecting those resources with switches or jumpers. As a result, you cannot set or change the card's base address. You can only determine what the system has assigned.

To determine the base address that has been assigned, run the PCIFind.EXE utility program provided. This utility will display a list of all of the cards detected on the PCI bus, the addresses assigned to each function on each of the cards, and the respective IRQs (if any) allotted.

Alternatively, some operating systems (Windows 95/98/2000/XP) can be queried to determine which resources were assigned. In these operating systems, you can use the Device Manager utility from the System Applet of the control panel. The card is installed in the Data Acquisition class of the Device Manager list. Selecting the card, clicking Properties, and then selecting the Resources Tab will display a list of the resources allocated to the card.

The PCI bus supports 64K of I/O space. Your card's addresses may be located anywhere in the 0000 to FFFF hex range.

PCIFind uses the Vendor ID and Device ID to search for your card, then reads the base address and IRQ.

If you want to determine the base address and IRQ yourself, use the following information.

The Vendor ID for the card is 494F. (ASCII for "IO")

The Device ID for the card is 10E8h.

## Chapter 5: Programming

### Sample Programs

There are sample programs provided with the card in C, Pascal, QuickBASIC, and several Windows languages. DOS samples are located in the DOS directory and Windows samples are located in the WIN32 directory.

### Windows Programming

The card installs into Windows as COM ports. Thus the Windows standard API functions can be used. In particular:

- ▶ `CreateFile()` and `CloseHandle()` for opening and closing a port.
- ▶ `SetupComm()`, `SetCommTimeouts()`, `GetCommState()`, and `SetCommState()` to set and change a port's settings.
- ▶ `ReadFile()` and `WriteFile()` for accessing a port.

See the documentation for your chosen language for details.

Under DOS, the process is identical to programming any 16550- or 16750-compatible UART.



## Address Map

The core of the UART function is supplied by the EXAR XR16L788 chip.

This chip is 16550 and 16750 compatible, but has extra features that require communicating with an additional 8 registers per channel. For instance, it is necessary to set the "Auto RTS" function. (EXAR refers to this function as "Auto RS485" in their literature). The required writing to the UART is done automatically when the card is rebooted.

In order to utilize standard software that communicates only with the first 8 registers of each channel, addresses are remapped on the card.

The 8 UARTS occupy the first 64 addresses.

The interrupt status register is located at base + 40h.

## Baud Rates

On the card, the UART clock frequency is 1.8432 MHz. Below is a table of popular divisor frequencies.

Baud Rate	Divisor x1	Divisor x8	Max Diff. Cable Length*
921600	-	1	250 ft
460800	-	2	550 ft
230400	-	4	1400 ft
153600	-	6	2500 ft
115200	1	8	3000 ft
57600	2	16	4000 ft
38400	3	24	4000 ft
28800	4	32	4000 ft
19200	6	48	4000 ft
14400	8	64	4000 ft
9600	12	96 – Most Common	4000 ft
4800	24	192	4000 ft
2400	48	384	4000 ft
1200	96	768	4000 ft

\*These are theoretical maximums based on typical conditions and good quality cables, based on the EIA 485 and EIA 422 standard for balanced differential drivers. The maximum cable length allowable for RS-232 communications is 50 feet due to single-ended line driver signaling.

**Table 5-1:** Baud Rate Divisor Values

## Chapter 6: Connector Pin Assignments

### Input/Output Connections

The card's Serial Communications card uses eight individual 9-pin connectors, provided via a spider cable from a 68-pin HVDCI D-connector.

To ensure that there is minimum susceptibility to EMI and minimum radiation, it is important that the card mounting bracket be properly screwed into place and that there be a positive chassis ground. Also, proper EMI cabling techniques (cable connect to chassis ground at the aperture, shielded twisted-pair wiring, etc) be used for the input/output wiring.

DB-9 Male Pin for each of Ch A-G	RS-232 Signals (Industry Standard)	RS-485 Signals (2 Wire)	RS-422 Signals (Also 4wire RS485)
Ch x - 1	DCD	RX-/TX- <sup>1</sup>	RX-
Ch x - 2	RX	TX+/RX+ <sup>1</sup>	TX+
Ch x - 3	TX	TX-/RX- <sup>1</sup>	TX-
Ch x - 4	DTR		
Ch x - 5	Gnd	Gnd	Gnd
Ch x - 6	DSR		
Ch x - 7	RTS		
Ch x - 8	CTS		
Ch x - 9	RI	RX+/TX+ <sup>1</sup>	RX+

**Table 6-1:** Connector Pin Assignments

<sup>1</sup> RS485 (2 wire) requires the installation of jumpers on the card to properly connect these pins. When using the spider cable, the appropriate DB 9 connectors will have pin 1 connected to pin 3 and pin 2 is connected to pin 9.

## Chapter 7: Specifications

### Communications Interface

- I/O Connection: 68 Pin HVDCI SCSI style -Connector
- Serial Ports: Eight leg breakout cable terminated with shielded male D-sub 9-pin standard IBM AT connectors compatible with RS485 specifications
- Character length: 5, 6, 7, or 8 bits.
- Parity: Even, odd or none.
- Stop Interval: 1, 1.5, or 2 bits.
- Serial Data Rates: Up to 115,200 baud, Asynchronous, A faster range of rates, up to 921,600, is achieved by jumper selection on the card. Type 16788 buffered UART. The RS-232 drivers used are specified as capable of 1Mbps. The highest baud rate achievable using the standard oscillator and divisor is 921.6kbps.
- Address: Continuously mappable within 0000 to FFFF (hex) range of PCI bus addresses.
- Receiver Input Sensitivity: +200 mV, differential input.
- Common Mode Rejection: +12V to -7V
- Transmitter Output Drive Capability: 60 mA, with thermal shutdown.

### Environmental

- Operating Temp.: 0 °C. to +60 °C.
- Storage temperature: -50 °C. to +120 °C.
- Humidity: 5% to 95%, non-condensing.
- Power Required: +5VDC at 125 mA typical total power consumption.
- Size: 6.6 inches long (167.6 mm) by 2.2 inches high (55.8 mm).

### Note

The 16750 compatible UART uses 64-byte first-in-first-out buffers which are programmed through commands sent to the FIFO control register.

## Appendix A: Application Considerations

### Introduction

Working with RS422 and RS485 devices is not much different from working with standard RS232 serial devices and these two standards overcome deficiencies in the RS232 standard. First, the cable length between two RS232 devices must be short; less than 50 feet at 9600 baud. Second, many RS232 errors are the result of noise induced on the cables. The RS422 standard permits cable lengths up to 5000 feet and, because it operates in the differential mode, it is more immune to induced noise.

Connections between two RS422 devices (with CTS ignored) should be as follows:

Device #1		Device #2	
Signal	Pin No.	Signal	Pin No.
Gnd	5	Gnd	5
TX <sup>+</sup>	2	RX <sup>+</sup>	9
TX <sup>-</sup>	3	RX <sup>-</sup>	1
RX <sup>+</sup>	9	TX <sup>+</sup>	2
RX <sup>-</sup>	1	TX <sup>-</sup>	3

**Table A-1:** Connections Between Two RS422 Devices

A third deficiency of RS232 is that more than two devices cannot share the same cable. This is also true for RS422 but RS485 offers all the benefits of RS422 plus allows up to 32 devices to share the same twisted pairs. An exception to the foregoing is that multiple RS422 devices can share a single cable if only one will talk and the others will all receive.

### Balanced Differential Signals

The reason that RS422 and RS485 devices can drive longer lines with more noise immunity than RS232 devices is that a balanced differential drive method is used. In a balanced differential system, the voltage produced by the driver appears across a pair of wires. A balanced line driver will produce a differential voltage from +2 to +6 volts across its output terminals. A balanced line driver can also have an input "enable" signal that connects the driver to its output terminals. If the "enable" signal is OFF, the driver is disconnected from the transmission line. This disconnected or disabled condition is usually referred to as the "tristate" condition and represents a high impedance. RS485 drivers must have this control capability. RS422 drivers may have this control but it is not always required.

A balanced differential line receiver senses the voltage state of the transmission line across the two signal input lines. If the differential input voltage is greater than +200 mV, the receiver will provide a specific logic state on its output. If the differential voltage input is less than -200 mV, the receiver will provide the opposite logic state on its output. A maximum operating voltage range is from +6V to -6V allows for voltage attenuation that can occur on long transmission cables.

A maximum common mode voltage rating of +7V provides good noise immunity from voltages induced on the twisted pair lines. The signal ground line connection is necessary in order to keep the common mode voltage within that range. The circuit may operate without the ground connection but may not be reliable.

Parameter	Conditions	Min.	Max.
Driver Output Voltage (unloaded)		4V	6V
		-4V	-6V
Driver Output Voltage (loaded)	LD and LDGND	2V	
	jumpers in	-2V	
Driver Output Resistance			50Ω
Driver Output Short-Circuit Current			+150 mA
Driver Output Rise Time			10% unit interval
Receiver Sensitivity			+200 mV
Receiver Common Mode Voltage Range			+7V
Receiver Input Resistance			4KΩ

**Table A-2:** RS422 Specification Summary

To prevent signal reflections in the cable and to improve noise rejection in both the RS422 and RS485 mode, the receiver end of the cable should be terminated with a resistance equal to the characteristic impedance of the cable. (An exception to this is the case where the line is driven by an RS422 driver that is never "tristated" or disconnected from the line. In this case, the driver provides a low internal impedance that terminates the line at that end.)

**Note**

You do not have to add a terminator resistor to your cables when you use the card. Termination resistors for the RX+ and RX- lines are provided on the card and are placed in the circuit when you install the Ch X - LD jumpers. (See the Option Selection section of this manual.)

## RS485 Data Transmission

The RS485 Standard allows a balanced transmission line to be shared in a party-line mode. As many as 32 driver/receiver pairs can share a two-wire party line network. Many characteristics of the drivers and receivers are the same as in the RS422 Standard. One difference is that the common mode voltage limit is extended and is +12V to -7V. Since any driver can be disconnected (or tristated) from the line, it must withstand this common mode voltage range while in the tristate condition.

The following illustration shows a typical multidrop or party line network. Note that the transmission line is terminated on both ends of the line but not at drop points in the middle of the line.

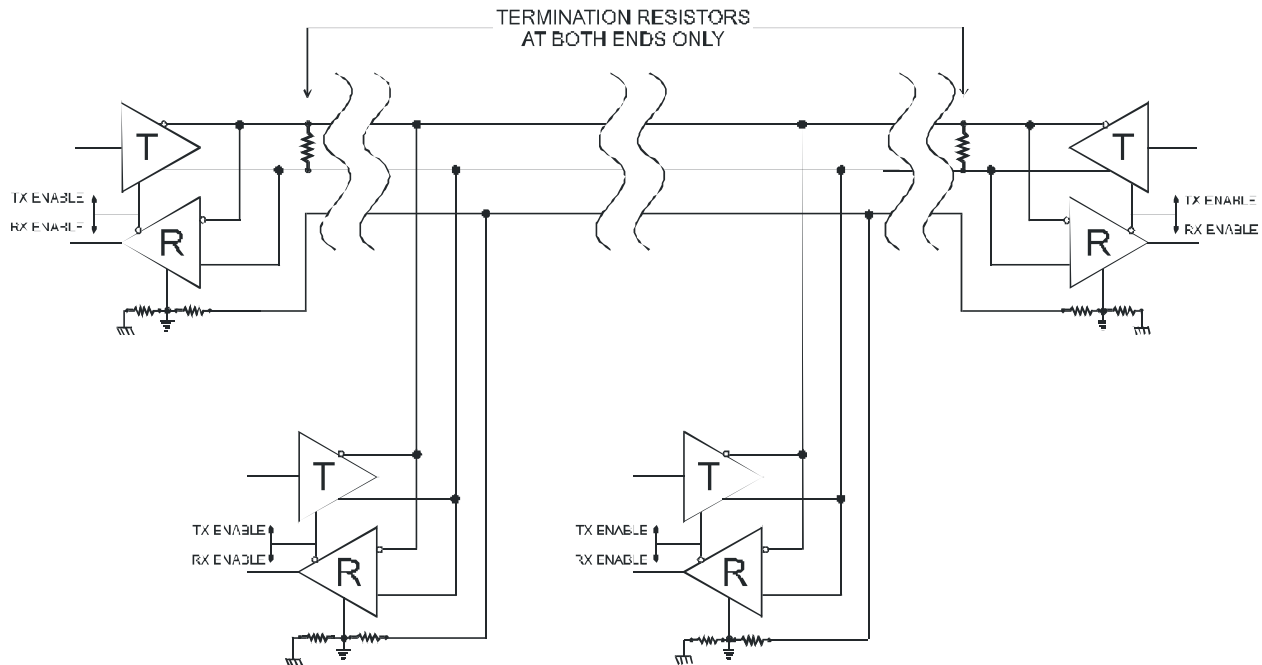

**Figure A-1:** Typical RS485 Two-Wire Multidrop Network

## RS485 Four-Wire Multidrop Network

An RS485 network can also be connected in a four-wire mode. In a four-wire network it's necessary that one node be a master node and all others be slaves. The network is connected so that the master communicates to all slaves and all slaves communicate only with the master. This has advantages in equipment that uses mixed protocol communications. Since the slave nodes never listen to another slave's response to the master, a slave node cannot reply incorrectly.

## Appendix B: HVDCI D-Connector Pinout Reference

Connections will normally be made to the 9-pin connectors through the breakout cable. In case you wish to connect directly to the 68-pin connector, the pins translate as follows.

DB-9 Pin	Ch A pins on 68-pin	Ch B Pins on 68-Pin	Ch C Pins on 68-Pin	Ch D Pins on 68-Pin	Ch E Pins on 68-Pin	Ch F Pins on 68-Pin	Ch G Pins on 68-Pin	Ch H Pins on 68-Pin
1	37	41	45	49	53	57	61	65
2	1	5	9	13	17	21	25	29
3	2	6	10	14	18	22	26	30
4	3	7	11	15	19	23	27	31
5	33 <sup>1</sup>	33 <sup>1</sup>	33 <sup>1</sup>	33 <sup>1</sup>	67 <sup>2</sup>	67 <sup>2</sup>	67 <sup>2</sup>	67 <sup>2</sup>
6	38	42	46	50	54	58	62	66
7	35	39	43	47	51	55	59	63
8	36	40	44	48	52	56	60	64
9	4	8	12	16	20	24	28	32

**Table B-1: HVDCI D-Connector Pin Assignments**

Pins 34 and 68 on the 68-pin HVDCI D-Connector provide +5Volts DC Fused, but are not available on any of the DB-9 connectors.

<sup>1</sup> Pin 33 on the 68-Pin connector is Ground, common to Pin 5 on each of the DB-9 connectors associated with COM Channels A, B, C, and D.

<sup>2</sup> Pin 67 on the 68-Pin connector is Ground, common to Pin 5 on each of the DB-9 connectors associated with COM Channels A, B, C, and D.

## Customer Comments

If you experience any problems with this manual or just want to give us some feedback, please email us at: ***manuals@acesio.com***. Please detail any errors you find and include your mailing address so that we can send you any manual updates.



10623 Roselle Street, San Diego CA 92121  
Tel. (858)550-9559 FAX (858)550-7322  
[www.acesio.com](http://www.acesio.com)